

Eclipse ThermJet Burners

Models TJ0015–TJ2000
Version 2

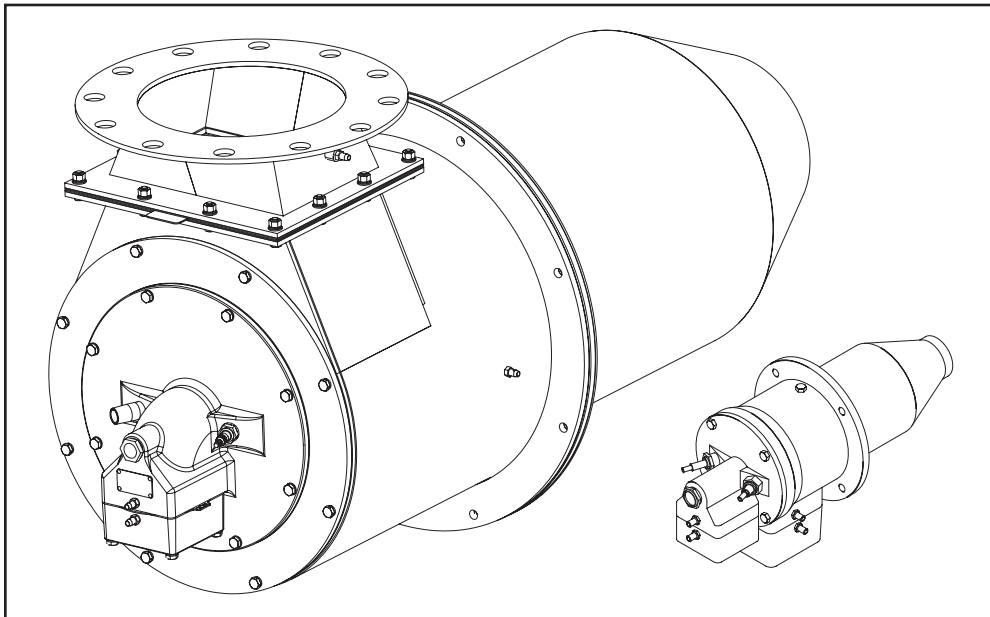

COPYRIGHT

Copyright 2007 by Eclipse, Inc. All rights reserved worldwide. This publication is protected by federal regulation and shall not be copied, distributed, transmitted, transcribed or translated into any human or computer language, in any form or by any means, to any third parties, without the express written consent of Eclipse, Inc.

In accordance with the manufacturer's policy of continual product improvement, the product presented in this brochure is subject to change without notice or obligation.

DISCLAIMER NOTICE

The material in this manual is believed adequate for the intended use of the product. If the product is used for purposes other than those specified herein, confirmation of validity and suitability must be obtained. Eclipse warrants that the product itself does not infringe upon any United States patents. No further warranty is expressed or implied.

We have made every effort to make this manual as accurate and complete as possible. Should you find errors or omissions, please bring them to our attention so that we may correct them. In this way we hope to improve our product documentation for the benefit of our customers. Please send your corrections and comments to our Marketing Communications Manager.

LIABILITY AND WARRANTY

It must be understood that Eclipse's liability for its product, whether due to breach of warranty, negligence, strict liability, or otherwise is limited to the furnishing of replacement parts and Eclipse will not be liable for any other injury, loss, damage or expenses, whether direct or consequential, including but not limited to loss of use, income, or damage to material arising in connection with the sale, installation, use of, inability to use, or the repair or replacement of Eclipse's products.

Any operation expressly prohibited in this Guide, any adjustment, or assembly procedures not recommended or authorized in these instructions shall void the warranty.



About this manual

AUDIENCE

This manual has been written for people who are already familiar with all aspects of a nozzle-mix burner and its add-on components, also referred to as “the burner system.”

These aspects are:

- Installation
- Use
- Maintenance

The audience is expected to have had previous experience with this kind of equipment.

THERMJET DOCUMENTS

Installation Guide No. 205

- This document

Data Sheet No. 205-I through 205-I3

- Available for individual TJ models
- Required to complete installation

Design Guide No. 205

- Used with Data Sheet to design burner system

Price List No. 205

- Used to order burners

RELATED DOCUMENTS

- EFE 825 (Combustion Engineering Guide)
- Eclipse bulletins and Info Guides:
610, 710, 720, 730, 742, 744, 760, 930, I-354.

Purpose

The purpose of this manual is to make sure that you carry out the installation of a safe, effective and trouble-free combustion system.

DOCUMENT CONVENTIONS

There are several special symbols in this document. You must know their meaning and importance.

The explanation of these symbols follows below. Please read it thoroughly.



Danger:

Indicates hazards or unsafe practices which WILL result in severe personal injury or even death.

Only qualified and well trained personnel are allowed to carry out these instructions or procedures.

Act with great care and follow the instructions.



Warning:

Indicates hazards or unsafe practices which could result in severe personal injury or damage.

Act with great care and follow the instructions.



Caution:

Indicates hazards or unsafe practices which could result in damage to the machine or minor personal injury, act carefully.



Note:

Indicates an important part of the text. Read thoroughly.

If you need help, contact your local Eclipse representative.

HOW TO GET HELP



Table of contents

1	Introduction	
	Product.....	7
	Description.....	7
	Figure 1.1 The ThermJet Burner	7
2	Safety	
	Introduction	8
	Safety.....	8
	Capabilities	9
	Operator Training.....	9
	Replacement Parts.....	9
3	Installation	
	Introduction	10
	Handling and Storage	10
	Position of Components	10
	Approval of Components	10
	Checklist Before Installation.....	12
	Prepare The Burner	13
	Burner Installation	15
	Figure 3.2: Firing Tubes and Combustion Blocks – Installation	15
	Piping Installation.....	16
	Valve Installation.....	17
	Checklist After Installation.....	18
	Prepare for Adjustment	18
4	Adjustment, Start & Stop	
	Introduction	19
	Modulating Gas and Air Ratio System.....	19
	Step 1: Reset the system	19
	Step 3: Set low fire air.....	21
	Step 4:Verify the air settings.....	21
	Step 5: Ignite the burners	21
	Step 6: Set high fire gas	22
	Step 7: Set low fire gas.....	22
	Step 8:Verify the gas settings.....	23

Fixed-air system	23
Step 1: Reset the system	23
Step 2: Set high fire air	23
Step 3: Ignite the burners	24
Step 4: Set high fire gas.....	25
Step 5: Set low fire gas.....	26
Step 6: Verify the gas settings.....	26
Set the bypass pilot gas (optional)	26
Start Procedure.....	27
Stop Procedure.....	27

5

Maintenance & Troubleshooting

Introduction	28
Monthly Checklist.....	28
Yearly Checklist.....	29
Troubleshooting Guide	30

Appendix

Conversion Factors	33
Illustrated Parts List.....	34
ThermJet Illustrated Parts Drawing (Models TJ0015 through TJ1000).....	35
ThermJet Illustrated Parts Drawing (Models TJ1500 and TJ2000).....	36
ThermJet Illustrated Parts List (Repeated)	37

Introduction

1

PRODUCT DESCRIPTION

The ThermJet is a nozzle-mix burner that is designed to fire an intense stream of hot gases through a combustor using ambient combustion air.

The high velocity of the gases improves temperature uniformity, product quality and system efficiency.

The ThermJet burner comes in two types:

- High Velocity (HV)
- Medium Velocity (MV)

The gas velocity can be as high as 500 ft/s for the High Velocity burner, and 250 ft/s for the Medium Velocity burner.

Figure 1.1 The ThermJet Burner

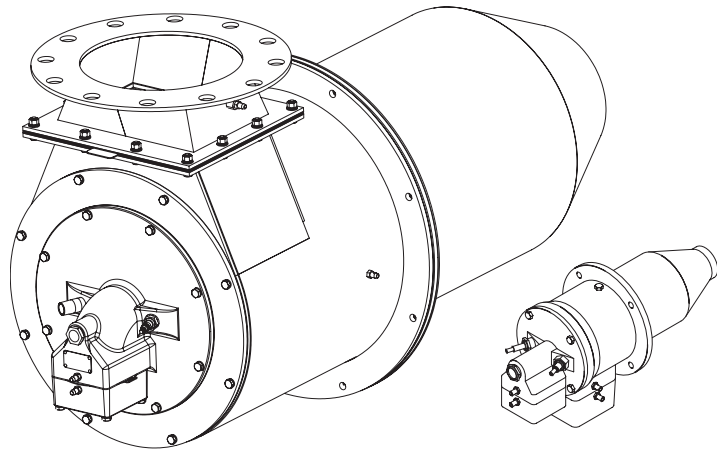

Safety

2

INTRODUCTION

SAFETY

In this section you will find important notices about safe operation of a burner system. Read this entire manual before you attempt to start the system. If you do not understand any part of the information in this manual, then contact your local Eclipse representative or Eclipse before you continue.



Danger:

The burners covered in this manual are designed to mix fuel with air and burn the resulting mixture. All fuel burning devices are capable of producing fires and explosions when improperly applied, installed, adjusted, controlled or maintained

Do not bypass any safety feature. You can cause fires and explosions.

Never try to light the burner if the burner shows signs of damage or malfunctioning.



Warning:

The burner is likely to have HOT surfaces. Always wear protective clothing when approaching the burner.



Note:

This manual gives information for the use of these burners for their specific design purpose. Do not deviate from any instructions or application limits in this manual without written advice from Eclipse.

SAFETY (CONTINUED)



Warning:

Eclipse products are designed to minimize the use of materials that contain crystalline silica. Examples of these chemicals are: respirable crystalline silica from bricks, cement or other masonry products and respirable refractory ceramic fibers from insulating blankets, boards, or gaskets. Despite these efforts, dust created by sanding, sawing, grinding, cutting, and other construction activities could release crystalline silica. Crystalline silica is known to cause cancer, and health risks from the exposure to these chemicals vary depending on the frequency and length of exposure to these chemicals. To reduce this risk, limit exposure to these chemicals, work in a well-ventilated area and wear approved personal protective safety equipment for these chemicals.

CAPABILITIES

Adjustment, maintenance and troubleshooting of the mechanical and the electrical parts of this system should be done by qualified personnel with good mechanical aptitude and experience with combustion equipment.

OPERATOR TRAINING

The best safety precaution is an alert and competent operator. Thoroughly instruct new operators so they demonstrate an adequate understanding of the equipment and its operation. Regular retraining must be scheduled to maintain a high degree of proficiency.

REPLACEMENT PARTS

Order replacement parts from Eclipse only. Any customer-supplied valves or switches should carry UL, FM, CSA, CGA and/or CE approval where applicable.

Installation

3

INTRODUCTION

HANDLING AND STORAGE

POSITION OF COMPONENTS

APPROVAL OF COMPONENTS

In this section you will find the information and instructions needed to install the burner and system components.

Handling

1. Make sure the area is clean.
2. Protect the components from weather, damage, dirt and moisture.
3. Protect the components from excessive temperatures and humidity.

Storage

1. Make sure the components are clean and free of damage.
2. Store the components in a cool, clean, dry room.
3. After making sure everything is present and in good condition, keep the components in original packages as long as possible.

The position and amount of components are determined by the kind of control method chosen. All the control methods can be found in Design Guide 205, Chapter 3 “System Design.” Use the schematics in that chapter to build your system.

Limit controls and safety equipment

All limit controls and safety equipment must comply with the current following standards:

- NFPA Standard 86
- NFPA Standard 86C
- UL
- FM
- CGA
- EN 746-2
- All applicable local codes and/or standards

APPROVAL OF COMPONENTS (CONTINUED)

Electrical wiring

All the electrical wiring must comply with one of these standards:

- NFPA Standard 70
- ANSI-C11981
- EN 746-2

The electrical wiring must also be acceptable to the local authority having jurisdiction.

Gas Piping

All the gas piping must comply with one of these standards:

- NFPA Standard 54
- ANSI Z223
- EN 746-2

The gas piping must also be acceptable to the local authority with jurisdiction.

Where To Get the Standards

The NFPA Standards are available from:

National Fire Protection Agency
Batterymarch Park
Quincy, MA 02269

The ANSI Standards are available from:

American National Standard Institute
1430 Broadway
New York, NY 10018

The UL Standards are available from:

333 Pfingsten Road
Northbrook, IL 60062

The FM Standards are available from:

1151 Boston-Providence Turnpike
P.O.Box 9102
Norwood, MA 02062

The CGA Standards are available from:

55 Scarsdale Road
Toronto, Ontario
Canada M3B 2R3

Information on the EN standards and where to get them is available from:

Comité Européen de Normalisation
Stassartstraat 36
B-1050 Brussels
Phone: +32-25196811
Fax: +32-25196819

Comité Européen de Normalisation Electronique
Stassartstraat 36
B-1050 Brussels
Phone: +32-25196871
Fax: +32-25196919

CHECKLIST BEFORE INSTALLATION

Intake

To admit fresh combustion air from outdoors, provide an opening in the room of at least one square inch per 4000 Btu/hr. If there are corrosive fumes or materials in the air, then supply the burner with clean air from an uncontaminated area.

Exhaust

Do not allow exhaust gases to accumulate in the work area. Provide some positive means for exhausting them from the furnace and the building.

Access

Make sure that you install the burner in such a way that you can get easy access for inspection and maintenance.

Environment

Make sure that the local environment matches the original operating specifications. Check the following items:

- Voltage, frequency and stability of the electrical power
- Type and supply pressure of the fuel
- Availability of enough fresh, clean combustion air
- Humidity, altitude and temperature of air
- Presence of damaging corrosive gases in the air

PREPARE THE BURNER

Several components must be installed to a burner before it can operate. Installation instructions follow:

It is possible to change the relative position of the gas inlet with respect to the air inlet. This can be convenient for the routing of the piping.

Rotate the rear cover (optional)

To rotate the rear cover, do the following:

1. Disconnect the piping at a union in the piping or the inlet flanges **1** provided on the burner.



Note:

Be careful not to lose or damage the orifice plate or the O-rings.

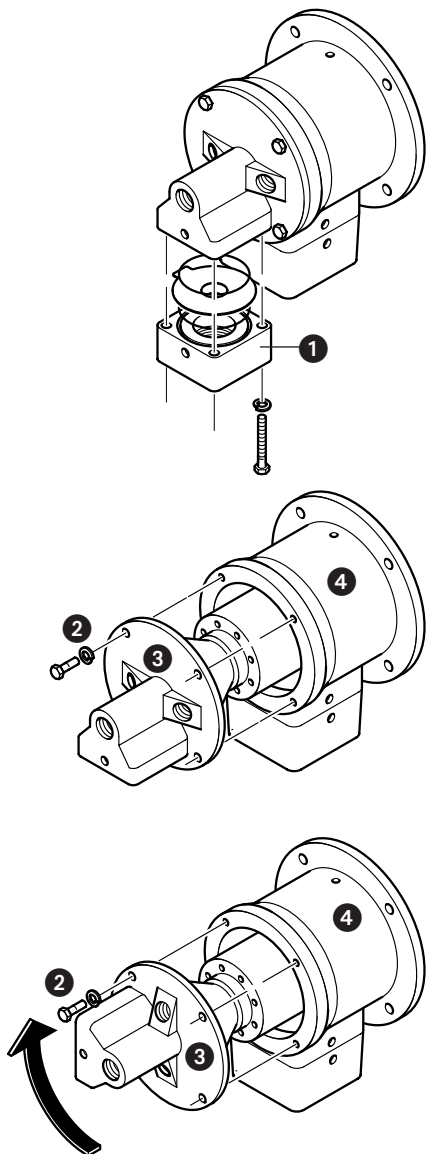

2. Remove the four bolts **2**.
3. Remove the rear cover **3** from the burner housing **4**.
4. Rotate the rear cover **3** to the position that you want.
5. Put the rear cover in position against the burner housing **4**.
6. Install the four bolts **2**.
7. Reconnect the piping. Make sure that the O-rings show no signs of damage.

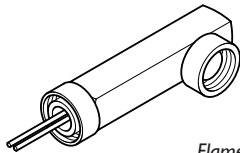
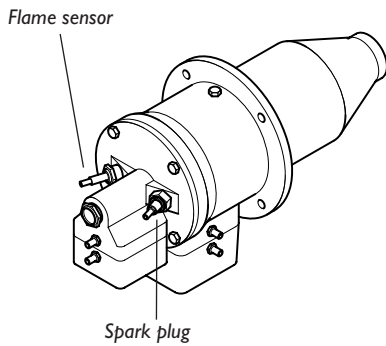

Flame sensor;
90° UV scanner

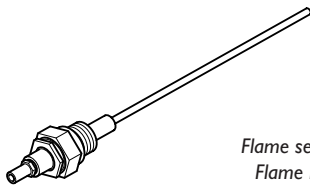

Flame sensor;
Flame rod

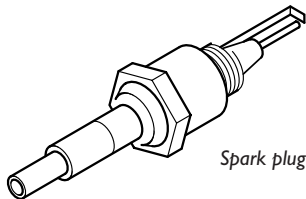

Spark plug

Installing The Flame Sensor

1. Install the flame sensor into the 1/2" NPT opening in the rear cover.
2. Make sure that you connect the flame sensor of a burner to the electrical circuit of that burner.



Danger:

If you connect the flame sensor of a burner to the electrical circuit of the wrong burner, then you can cause fires and explosions.

There are two different types of flame sensors:

UV Scanner

For detailed information on how to install and connect a UV scanner, refer to:

- Bulletin/Info Guide 854 for straight UV scanners
- Bulletin/Info Guide 852 for 90° UV scanners
- Bulletin/Info Guide 856 for self-check UV scanners.

Flame Rod:



Note:

Only specific burner sizes with alloy or silicon carbide combustors can use a flame rod (see specific burner data sheets).

For detailed information on how to install and connect a flame rod, refer to Bulletin/Info guide 832.

Installing the spark plug

Install the spark plug into the opening in the rear cover.



Note:

*Do **not** apply any grease to the threads of the spark plug. You can cause bad grounding of the spark plug if you apply grease to it. Bad grounding of the spark plug results in a weak spark.*

BURNER INSTALLATION

Dimensions

The burner attaches to the wall of the **chamber** with bolts through holes "C". For full information on the dimensions, refer to specific data sheets.

Figure 3.1 Burner attachment

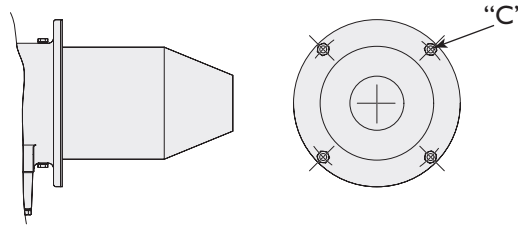

Chamber wall

Make sure that the wall of the chamber is strong enough to carry the weight of the burner. If necessary, reinforce the area where you plan to install the burner to support the weight of the burner.

Avoid losses

To make sure that heat does not go back to the casing of the chamber, it is important that the radial clearance around the firing tube is filled with ceramic fiber.

Figure 3.2 Firing Tubes and Combustion Blocks – Installation

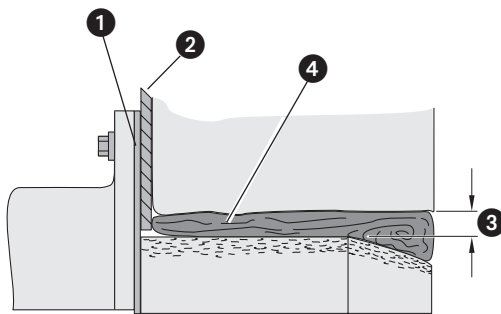

Alloy

1. Make sure the gasket **1** is installed between the burner and the chamber wall **2**.
2. Make sure that gasket **1** does not leak.
3. Check the size of the clearance. If the gap **3** around the firing tube is larger than 1/2", then pack the gap with ceramic fiber **4**, as stated above.

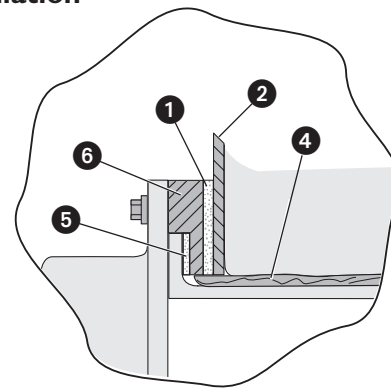

Silicon Carbide

1. Make sure the gasket **1** is installed between the burner flange and chamber wall **2**.
2. Make sure that gasket **5** is installed between SiC tube and flange **6**.
3. Make sure neither gasket **1** nor **5** leaks.
4. Check the size of the clearance. If the gap around the firing tube is larger than 1/2", then pack the gap with ceramic fiber **4**, as stated above.

Figure 3.2: Firing Tubes and Combustion Blocks – Installation (Continued)

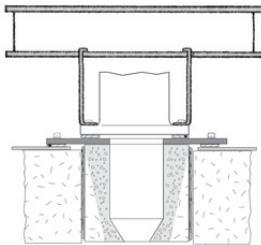
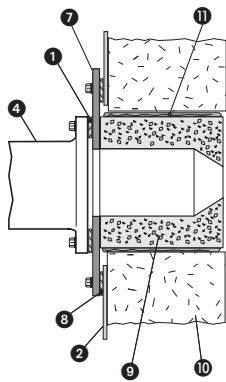

PIPING INSTALLATION

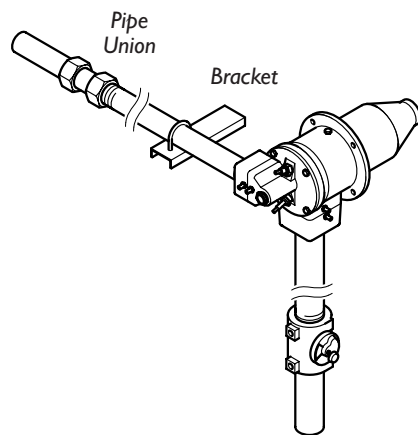

Refractory Block

1. Be sure the gasket **1** is installed between the burner **4** and the block holder **7**.
2. Be sure the gasket **8** is installed between the block holder **7** and the chamber wall **2**.
3. Support the weight of the refractory block **9** with hard brick work **10**. Fill space around the block **9** with soft gasket material **11**.

Vertical Down Firing Blocks

1. Down firing blocks may be suspended by customer-supplied hangers **2** attached to the burner body mounting bolts.
2. Hangers should be attached to structural support **1**.

Layout

Install the piping as shown in the schematics. Refer to Chapter 3 of the ThermJet Design Guide No. 205.

Support the piping

Use brackets or hangers to support the gas piping. If you have questions, consult your local gas company.

Straight run of pipe before a metering orifice



Note:

There must be a run of pipe with a straight length of at least 10 pipe diameters before the burner metering orifice. If you do not do this, the pressure readings **will** be inaccurate.

Pipe connections

1. Install a pipe union in the gas line to the burner. This simplifies removal of the burner.
2. The use of flexible pipe nipples in the gas line to the burner is optional. Flexible nipples can absorb stress due to heat expansion and slight misalignment.



Note:

Flexible pipe nipples will cause inaccurate metering orifice readings and may cause higher pressure drops than equivalent standard pipe. Consider this when you size the gas lines.

Avoid large pressure drops



Note:

The pressure drop of the gas in the piping is a critical parameter. Make sure that the size of all the piping is large enough to prevent excessive pressure losses.

VALVE INSTALLATION

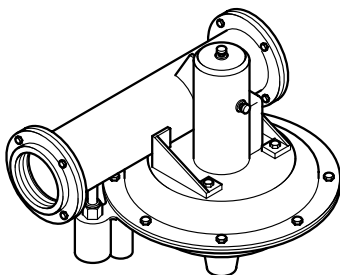
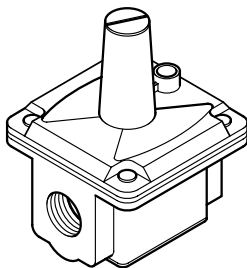
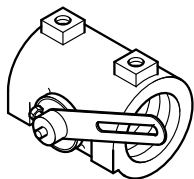
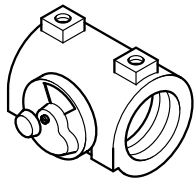
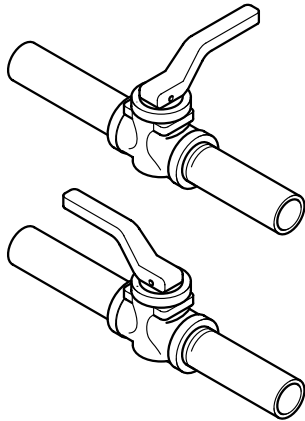

Valve orientation

Install all the valves in such a way that the arrow (if present) on the valve body points in the direction of flow.

Gas cocks

Make sure that the handle of a gas cock is at a right angle to the valve body when the valve is in the closed position. This is an important position indicator. If you do not do this, somebody may think that the gas cock is in the closed position, while it is actually in the open position.

Gas balancing valves

A gas balancing valve is typically the same as a manual butterfly valve. For more information, refer to the section below.

Manual butterfly valves

1. Install manual butterfly valves in accordance with Bulletin/Info Guide 720.
2. Install manual butterfly valves in the gas line to the burner (optional).



Note:

It is recommended that there is a run of pipe with a length of at least 10 pipe diameters between any flow altering device and the metering orifice on the burner.

Automatic butterfly valve

An automatic butterfly is driven by an actuator (actuator and mounting bracket not illustrated). Install the control valve in accordance with Bulletin/Info Guide 720.

Ratio regulator

- Connect an impulse line to the ratio regulator and to the air supply line.
- Install the ratio regulator in accordance with Bulletin/Info Guide 742.

CRS valve

Install the CRS valve in accordance with Bulletin/Info Guide 744.

CHECKLIST AFTER INSTALLATION

PREPARE FOR ADJUSTMENT

To verify proper system installation, do the following:

1. Make sure that there are no leaks in the gas lines and the air lines.
2. Make sure all the components of the flame monitoring control system are properly installed. This includes verifying that all switches are installed in correct locations and all wiring, pressure and impulse lines are properly connected.
3. Make sure components of spark ignition system are installed and functioning properly.
4. Make sure that the blower rotates in the correct direction. If incorrect, then have a qualified electrician rewire the blower to reverse its rotation.
5. Make sure all valves are installed in proper location and correctly oriented relative to the gas or air flow direction.

After installation of the burner system components is complete, the following steps should be followed in order to prepare for adjustment:

1. Set the air pressure switch so that it drops out at 4" w.c. (10 mbar) below the pressure rating of the blower.
2. Set the low gas pressure switch at 4" w.c. (10 mbar) below the gas pressure measured at the inlet to the main gas valve train.
3. Set the high gas pressure switch so that it comes on at 4" w.c. (10 mbar) above the gas pressure measured at the inlet to the main gas valve train.
4. Close all the burner gas cocks.
5. Try to light a burner before the purge and other timers have finished their cycles. Make sure that the flame monitoring system indicates a flame failure.
6. Trip out pressure switches and other limit interlocks. Make sure that the main gas valve train closes.



Danger:

If simulated limits or simulated flame failures do not shut down the fuel system within the required failure response time, immediately correct the problem before proceeding.

Adjustment, Start & Stop

4

INTRODUCTION

In this chapter you will find instructions on how to adjust a system, and how to start and stop a system. The chapter starts with general instructions that are useful for adjustment.



Danger

Do not bypass any safety feature. You can cause fires and explosions.

Obey the safety precautions in Chapter 2.

Adjustment

There are two adjustment procedures. To adjust a modulating gas and air ratio system, refer to “Modulating Gas and Air Ratio System” on page 18. For a fixed-air system, refer to “Fixed-air System” on page 22.

If you adjust an on-ratio system for the first time, you must follow these steps (Refer to Figure 3.1 and Figure 3.3 in the ThermJet Design Guide No. 205):

1. Reset the system
 2. Set high fire air
 3. Set low fire air
 4. Verify the air settings
 5. Ignite the burners
 6. Set high fire gas
 7. Set low fire gas
 8. Verify the gas settings.
-
1. Close these valves: the automatic gas valves and the gas cocks.
 2. Fully open the manual air butterfly valve at each burner.
 - a. Drive the automatic zone air control valve to high fire.
 - b. Adjust the automatic zone air control valve so that it is fully open. The automatic zone air control valve can be either a butterfly valve or a CRS valve.

MODULATING GAS AND AIR RATIO SYSTEM

Step 1: Reset the system

3. Start the blower.



Caution

Make sure that the blower rotates in the correct direction. If incorrect, have a qualified electrician rewire the blower to reverse its rotation.

1. Set the system to high fire, but **DO NOT** ignite the burner(s).
2. Use the air curves from the appropriate ThermJet Data Sheet to find the differential air pressure needed at high fire. This is now the target value for high fire.
3. Set high fire air.



Note

A pressure tap is open when the screw inside the tap is unscrewed approximately half a turn.

To set high fire air on a single burner system:

- a. Make sure that pressure taps A and C are open.
- b. Connect the manometer to taps A and C (across the air orifice).
- c. Adjust the manual butterfly valve until the high-fire differential air pressure is at the target value.
- d. Remove the manometer.
- e. Close the pressure taps.

To set high fire air on a multiple burner system:

- a. Make sure that pressure taps A and C of the first burner are open.
- b. Connect the manometer to taps A and C of the first burner (across the air orifice).
- c. Adjust the zone air manual butterfly valve to achieve the target value for the first burner.
- d. Measure and note the differential air pressure across the next burner in the zone.
- e. Repeat d for all the other burners in the zone (if any).
- f. If all the measured differential pressures are within 0.3" w.c. (0.75 mbar) of each other, then proceed to the next section. If the variation is greater than 0.3" w.c. (0.75 mbar) it will be necessary to adjust the manual air butterfly valve at each burner to improve the balance.
- g. Make sure that all the pressure taps are closed.

4. Repeat 3. for other zones (if any).

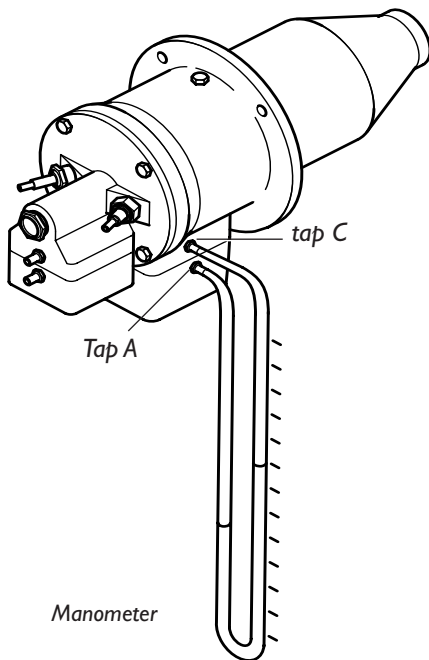

Step 3: Set low fire air

Step 4: Verify the air settings

Step 5: Ignite the burners

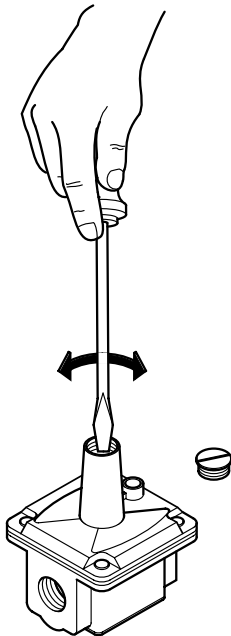

1. Set the system to low fire.
2. Connect the manometer to tap A (air inlet pressure tap).
3. Adjust the automatic zone air control valve until the low-fire static air pressure is 0.2" w.c. This is the initial setting only. Further adjustment may be required.
4. Repeat 2 and 3 for the other zones (if any).

Make sure all the settings are still the same after you cycle the system several times between high and low fire.



Warning:

This procedure assumes that a flame monitoring control system is installed and is serviceable. It also assumes that normal low fire start is being used. If low fire gas is too low to be used for ignition, refer to options in "Set the bypass pilot gas (optional)" on page 25.

1. Drive the zone air automatic control valve to low fire.
2. Make sure the combustion air blower is running.
3. Set the manual gas butterfly valve at each burner to 50% open.
4. Set the adjusting screw on the ratio regulator six full (360°) turns down from the top (initial setting).
5. Open zone manual gas cock.
6. Open manual gas cock at each burner.
7. Initiate the ignition sequence through the flame monitoring control system.
 - a. Check that all the burners in the zone have ignited.
 - b. If safety shut-off solenoid valves are installed at each burner, then repeat 6 and 7 for all the burners in the zone.
8. If all the burners have ignited, drive the zone air butterfly valve to high fire. Verify flame is present at each burner. If burners do not light, add a 1/2 turn down on the proportionator, repeat steps 7 through 11.
9. Verify that air pressure drops have remained the same.
10. If air pressure drop is too high, close down the zone manual air butterfly valve.
11. If air pressure drop is too low, open the zone manual air butterfly valve.

Step 6: Set high fire gas

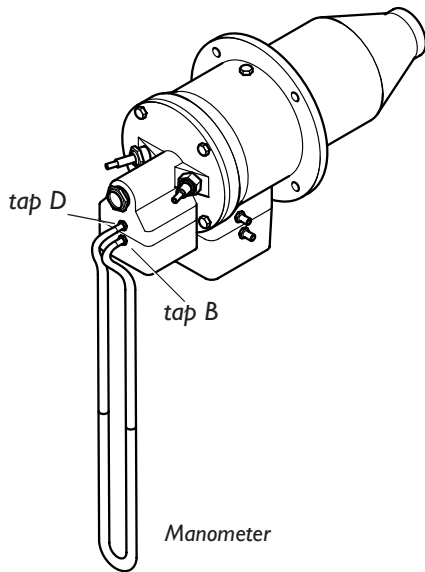

Step 7: Set low fire gas

1. Use the gas curve from the appropriate ThermJet Data Sheet for the gas being used to find the differential gas pressure needed at high fire. This is the target value for high fire.
2. Connect the manometer to taps B and D (across the gas orifice).
3. Measure the high fire differential gas pressure for the first burner.
4. Adjust the gas butterfly valve at the burner until the gas flow is at the target value.
5. Repeat 3 thru 4 for the other burners in the zone.
6. Check the gas pressure at the inlet to the zone ratio regulator. This should be at least 5" w.c. (12.5 mbar) higher than the loading line pressure. It should not exceed the maximum pressure rating of the ratio regulator.



Warning:

Insufficient gas inlet pressure may cause the proportionator to remain fully open as the burner system turns down from high fire, causing excess fuel operation and the possible accumulation of unburned fuel in the chamber. In extreme cases, this may cause explosions or fires.

1. Drive the system to low fire.
2. Use the gas curve from the appropriate ThermJet Data Sheet for the gas being used to determine the differential gas pressure required for low fire. This is your target value for low fire.
3. Measure the gas pressure at the first burner.
4. Adjust the ratio regulator until the gas flow is on the target value. (Refer to Bulletin 742 for adjustment.)



Note:

It is very difficult to measure the very low pressures experienced at low fire, and it may be necessary to rely on visual inspection. This is especially true when gas turndowns in excess of 10 to 1 are being used. The main intent is to provide a clean stable flame with a good flame signal that will not cause the furnace temperature to overshoot.

If the pressure required is too low to be measured, then adjust the ratio regulator until a gas flow is obtained that will provide a clean stable flame with a strong flame signal.

Step 8: Verify the gas settings

Make sure that all settings are still the same after cycling the system several times between high and low fire.



Note:

When all the settings have been completed, mark the position of the indicator on the butterfly valves to indicate valve position.

FIXED-AIR SYSTEM

When you adjust a fixed-air system for the first time, you must follow these steps (Refer to Figure 4.2 and Figure 4.4):

1. Reset the system
2. Set high fire air
3. Ignite the burners
4. Set high fire gas
5. Set low fire gas
6. Verify the gas settings

Step 1: Reset the system

1. Close the automatic gas valves and the gas cocks.
2. Fully open the manual air butterfly valve at each burner.
 - a. Drive the automatic zone air control valve to high fire.
 - b. Adjust the automatic zone air control valve so that it is fully open. The automatic zone air control valve can be either a butterfly valve or a CRS valve.
3. Set the manual gas butterfly valve at each burner to 50% open.
4. Start the blower.



Note:

Make sure that the blower rotates in the correct direction. If incorrect, then have a qualified electrician rewire the blower to reverse its rotation.

Step 2: Set high fire air

1. Set the system to high fire, but **DO NOT** ignite the burner(s).
2. Use the air curves in “Orifice curves” from the appropriate ThermJet Data Sheet to find the differential air pressure needed at high fire. This is now the target value for high fire.
3. Set high fire air.



Note:

A pressure tap is open when the screw inside the tap is unscrewed approximately half a turn.

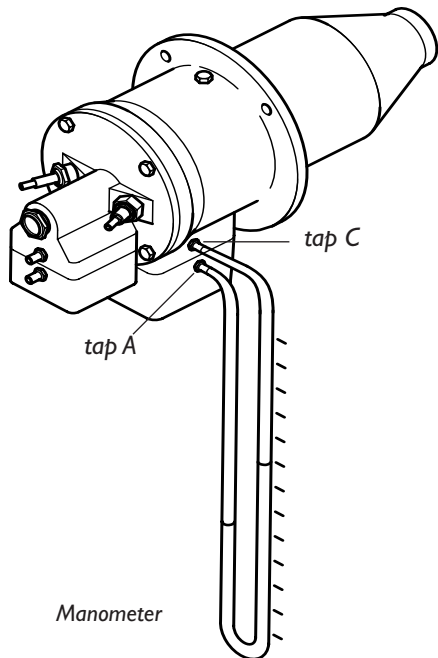

Step 3: Ignite the burners

Single Burner System:

- Make sure that pressure taps A and C of the burner are open.
- Connect the manometer to taps A and C (across the air orifice).
- Adjust the manual butterfly valve until the high-fire differential air pressure is at the target value.
- Remove the manometer.
- Close the pressure taps.

Multiple Burner System:

- Make sure that pressure taps A and C of the first burner are open.
 - Connect the manometer to taps A and C of the first burner (across the air orifice).
 - Adjust the manual butterfly valve for the zone, until the high-fire differential air pressure is at the target value for the first burner.
 - Measure the differential air pressure across the next burner in the zone.
 - Repeat step d for all the other burners in the zone (if any).
 - If all the measured differential pressures are within 0.3" w.c. (0.75 mbar) of each other, then proceed to the next section. If the variation is greater than 0.3" w.c. (0.75 mbar) it will be necessary to adjust the manual air butterfly valve at each burner to improve the balance.
 - Make sure that all the pressure taps are closed.
4. Repeat 3 for other zones (if any).



Warning:

This procedure assumes that a flame monitoring control system is installed and is serviceable. It also assumes that normal low fire start is being used.

If low fire gas is too low to be used for ignition, refer to options in "Set the bypass pilot gas (optional)" on page 25.

- Drive the zone gas automatic butterfly valve to low fire.
- Make sure the combustion air blower is running.
- Set the burner manual gas butterfly valve to low fire.

4. Set the adjusting screw on the ratio regulator six full (360°) turns down from the top (initial setting).
5. Select the valve according to the control method:
 - a. **With high/low control:**
Set the gas bypass butterfly valve 25% open.
 - b. **With modulating gas control:**
Set the zone gas automatic butterfly valve to approximately 10% open. Stroke the valve to the open position to ensure 100% open. Readjust if necessary.
6. Open the zone gas manual gas cock.
7. Open the manual gas cock at each burner.
8. Initiate the ignition sequence through the flame monitoring control system.
9. Check that all the burners in the zone have ignited.
10. If shut-off solenoid valves are installed at each burner, then repeat 6 and 7 for all the burners in the zone.
11. If all the burners have ignited, drive the zone to high fire. Verify flame is present at each burner.

Step 4: Set high fire gas

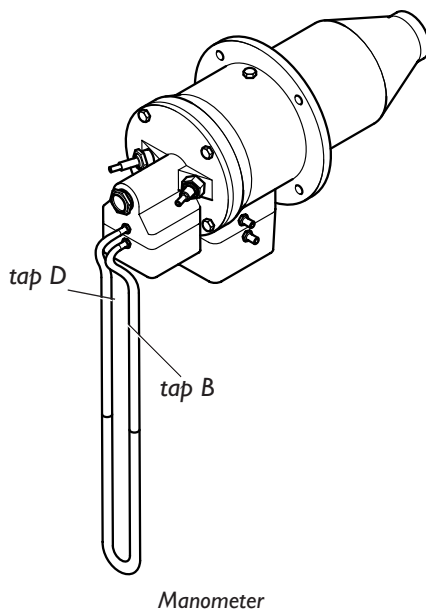

1. Use the gas curves from the appropriate ThermJet Data Sheet for the gas being used to find the differential gas pressure needed at high fire. This is the target value for high fire.
2. Connect the manometer to taps B and D (across the gas orifice).
3. Measure the high fire differential gas pressure for the first burner.
4. Adjust the gas butterfly valve at the burner until the gas flow is at the target value.
5. Repeat 3 and 4 for the other burners in the zone.
6. Check the gas pressure at the inlet to the zone ratio regulator. This should be at least 5" w.c. (12.5 mbar) higher than the loading line pressure. It should not exceed the maximum pressure rating of the ratio regulator (optional).

Step 5: Set low fire gas

1. Drive the system to low fire.
2. Measure the gas pressure drop at the first burner.
3. Select the valve according to the control method:
 - a. **With high/low control:**
Adjust the gas bypass butterfly valve (see ThermJet Design Guide No. 205) until the minimum fire that will still maintain a strong flame signal is obtained.
 - b. **With modulating gas control:**
Adjust the zone gas automatic butterfly valve (see ThermJet Design Guide No. 205) until the minimum fire that will still maintain a strong flame signal is obtained.



Note:

It is very difficult to measure the very low pressures experienced at low fire, and it may be necessary to rely on visual inspection. This is especially true when gas turndowns in excess of 10 to 1 are being used. The main intent is to provide a clean stable flame with a good flame signal that will not cause the furnace temperature to overshoot.

Make sure that all the settings are still the same after you have cycled the system several times between high and low fire.

Step 6: Verify the gas settings



Note:

When all the settings have been completed, mark the position of the indicator on the butterfly valves to indicate valve position.

1. Set the system to low fire.
2. Make sure that the blower is on.



Warning:

Before you perform this procedure, make sure the flame monitoring control system is working.

3. Use the flame monitoring control system to start the ignition and the bypass pilot gas for all the burners in the zone.
4. Adjust the manual butterfly valve in the bypass line until you obtain reliable ignition within the required trial for ignition time limit.
5. Repeat 4 for all the other burners and zones (if any).

SET THE BYPASS PILOT GAS (OPTIONAL)

START PROCEDURE

1. Start the blower.
2. Open all the gas cocks.
3. Start the ignition sequence.
4. Verify that flame is present at each burner.



Danger:

If a burner does not light, and the system does not shut down automatically, then you must close the main gas cock. An uncontrolled flow of gas can cause fires and explosions.

Do not touch the ignition plug or the ignition wire when the ignition is on. You will get a shock.

STOP PROCEDURE

1. Close the following valves:
 - The manual gas cock for each burner or zone
 - The manual gas cock at the main control valve
 - All the manual shut-off valves in the gas line upstream of the burner gas cock
2. Let the burners cool down. Keep the blower on until the chamber temperature is less than 1000° F (500° C) and then stop the blower.



Note:

Keeping the blower on after the burner is off protects the burner and the other components from hot gases that flow back through the burner.

Maintenance & Troubleshooting 5

INTRODUCTION

This section is divided into two parts:

- The first part describes the maintenance procedures.
- The second part helps identify problems that may occur, and gives advice on how to solve these problems.

MAINTENANCE

Preventive maintenance is the key to a reliable, safe and efficient system. The core of any preventive maintenance program is a list of periodic tasks.

Following are suggestions for a monthly list and a yearly list.



Note:

The monthly list and the yearly list are an average interval. If your environment is dirty, then the intervals may be shorter.

MONTHLY CHECKLIST

1. Test (leak test) safety shut-off valves for tightness of closure.
2. Test air pressure switch settings by checking switch movements against pressure settings and comparing with actual impulse pressure.
3. Visually check ignition cable and connectors.
4. Inspect impulse piping for leaks.
5. Remove, clean and inspect all the burners.
6. Make sure that the following components are not damaged or distorted:
 - the burner nozzle
 - the spark plugs
 - the flame sensors
 - the flame tube or combustion block
7. If applicable, remove and clean all the orifice plates.

YEARLY CHECKLIST

1. Inspect flame-sensing devices for good condition and cleanliness.
2. Check for proper inlet air/gas ratios.
3. Test all the alarm systems for proper signals.
4. Check ignition spark plugs and check proper gap.
5. Check valve motors and control valves for free, smooth action and adjustment.
6. Check for proper operation of the ventilating equipment.
7. Test the interlock sequence of all safety equipment; manually make each interlock fail, noting that related equipment closes or stops as specified by the manufacturer.
8. Test flame monitoring control system by manually shutting off gas to burner.
9. Test main fuel hand-valves for operation.
10. Clean or replace the combustion air blower filter.

TROUBLESHOOTING GUIDE

PROBLEM	POSSIBLE CAUSE	SOLUTION
Cannot initiate start sequence	<ul style="list-style-type: none"> Air pressure switch has not made contact 	Check air-pressure switch adjustment Check air filter Check blower rotation Check outlet pressure from blower
	<ul style="list-style-type: none"> High gas pressure switch has tripped 	Check incoming gas pressure Adjust gas pressure if necessary Check pressure switch setting and operation
	<ul style="list-style-type: none"> Low gas pressure switch has tripped 	Check incoming gas pressure Adjust gas pressure if necessary Check pressure switch setting and operation
	<ul style="list-style-type: none"> Malfunction of flame monitoring control system such as shorted out flame sensor or electrical noise in the sensor line. 	Have a qualified electrician investigate and rectify.
	<ul style="list-style-type: none"> Purge cycle not completed 	Check flame monitoring control system or purge timer.
	<ul style="list-style-type: none"> Main power is off 	Make sure power is on to control system
	<ul style="list-style-type: none"> No power to control unit 	Call qualified electrician to investigate.

TROUBLESHOOTING GUIDE (CONTINUED)

PROBLEM	POSSIBLE CAUSE	SOLUTION
Start-up sequence runs but burner does not light	No ignition: • There is no power to the ignition transformer	Restore power to the ignition transformer
	No ignition: • Open circuit between the ignition transformer and the spark plug	Repair or replace the wiring to the spark plug
	No ignition: • The spark plug needs cleaning	Clean the spark plug
	No ignition: • The spark plug is not correctly grounded to the burner	Clean the threads of the spark plug and the burner Do not apply grease to the thread of the spark plug
	Too much gas: • Improper gas valve train sequence.	Verify solenoid valve is downstream of proportionator
	Too much gas: • Manual gas butterfly valves have been opened too far	Check pressures and settings against start-up report and adjust as necessary
	Too much gas: • Gas pressure out of the main gas pressure regulator is too high	Check start-up setting If necessary, remove regulator and investigate
	Not enough gas: • The gas pressure out of the main gas pressure regulator is too low	Check start-up setting Check regulator & adjust if necessary
	Not enough gas: • Start gas solenoid valve does not open	Check solenoid valve coil for proper operation. Replace if necessary
	Not enough gas: • Gas valve not open	Check wiring to the automatic gas shut-off valve
Not enough gas: • Air in the gas line	Check output from the flame safeguard Open gas cock Purge gas line	

TROUBLESHOOTING GUIDE (CONTINUED)

PROBLEM	POSSIBLE CAUSE	SOLUTION
The low fire flame is weak or unstable	• Low fire adjusted too low	Increase low fire gas setting
	• Not enough gas	Check start-up settings and adjust to increase low gas flow
	• Not enough air	Check start-up settings. Investigate any change, i.e. blocked filter, loose connections
The burner goes off when it cycles to high fire	• Insufficient air (flame too rich)	Check start-up settings Check air filter, clean or replace if required
The burner is erratic and does not respond to adjustment	• Flame signal weak	Check condition of flame monitoring device
	• Internal damage to the burner. Some parts inside the burner may be loose or dirty	Contact your Eclipse representative or the Eclipse factory
The burner is unstable or produces soot or smoke	• The air/gas ratio is out of adjustment	Measure all the gas pressures and air pressures. Compare to initial start-up settings, and adjust them where necessary
Cannot achieve full capacity	• Air filter is blocked	Clean or replace the air filter
	• Gas pressure is too low into the main gas pressure regulator	Adjust gas pressure
	• Increased furnace/chamber pressures	Re-check setup pressures
	• Poor piping practices	Contact factory



Appendix

CONVERSION FACTORS

Metric to English.

FROM	To	MULTIPLY BY
cubic meter (m ³)	cubic foot (ft ³)	35.31
cubic meter/hour (m ³ /h)	cubic foot/hour (cfh)	35.31
degrees Celsius (°C)	degrees Fahrenheit (°F)	(°C × 1.8) + 32
kilogram (kg)	pound (lb)	2.205
kilowatt (kW)	Btu/hr	3414
meter (m)	foot (ft)	3.28
millibar (mbar)	inches water column ("wc)	0.401
millibar (mbar)	pounds/sq in (psi)	14.5 × 10 ⁻³
millimeter (mm)	inch (in)	3.94 × 10 ⁻²

Metric to Metric.

FROM	To	MULTIPLY BY
kiloPascals (kPa)	millibar (mbar)	10
meter (m)	millimeter (mm)	1000
millibar (mbar)	kiloPascals (kPa)	0.1
millimeter (mm)	meter (m)	0.001

English to Metric.

FROM	To	MULTIPLY BY
Btu/hr	kilowatt (kW)	0.293 × 10 ⁻³
cubic foot (ft ³)	cubic meter (m ³)	2.832 × 10 ⁻²
cubic foot/hour (cfh)	cubic meter/hour (m ³ /h)	2.832 × 10 ⁻²
degrees Fahrenheit (°F)	degrees Celsius (°C)	(°F - 32) ÷ 1.8
foot (ft)	meter (m)	0.3048
inches (in)	millimeter (mm)	25.4
inches water column ("wc)	millibar (mbar)	2.49
pound (lb)	kilogram (kg)	0.454
pounds/sq in (psi)	millibar (mbar)	68.95

ThermJet Illustrated Parts List

Pos. No.	Qty.	Description	TJ0015	TJ0025	TJ0040	TJ0050	TJ0075	TJ0100	TJ0150	TJ0200	TJ0300	TJ0500	TJ0750	TJ1000	TJ1500	TJ2000
1	1	Gasket, Mounting	17054	17054	17054	20422	20422	14932	14932	14932	10027	20151	10002831	10002831	10007206	10007206
2	2	Screw	16022	16022	16022	16022	16022	16022	16022	16022	N/A	N/A	N/A	N/A	N/A	N/A
3	1	Body	7031-1	7031-1	7118-1	7046-1	7046-1	3994	3994	3994	7036-1	7111-1	7124-3	7124-3	10006927	10006927
4	1	Nozzle, Cast Iron	7033-1	7033-2	7033-3	7133-1	7133-2	3997-1	3997-1	3997-1	7038-1	7116-1	10002813-1	10002813-1	10006112	10006112
5	1	Nozzle, Stainless Steel	7125-1	7125-2	7125-3	7137-1	7137-1	7127-1	7127-1	7127-1	7128-1	7129-1	10007413-1	10007413-1	10007512	10007512
6	1	Nozzle, Cast Iron, For Block	10026919	10026920	10026921	10026922	10026923	10026924	10026925	10026925	N/A	N/A	N/A	N/A	N/A	N/A
7	1	Nozzle, Stainless Steel, For Block	10026926	10026927	10026928	10026929	10026930	10026931	10026932	10026931	N/A	N/A	N/A	N/A	N/A	N/A
8	2	Set Screw	19969	19969	19969	15885	15885	15885	15885	15885	15885	15885	21598	21598	21598	21598
9	2	Stainless Set Screw	10024662	10024662	10024662	10024356	10024356	10024356	10024356	10024356	10024356	10024356	10024663	10024663	10024663	10024663
10	1	Rear Cover	7032-1	7032-1	7032-1	3998-1	3998-1	3995	3995	3995	18933	18933	10002812	10002812	10002812	10002812
11	4	Screw, #2 Drive	18933	18933	18933	18933	18933	18933	18933	18933	18933	18933	18933	18933	18933	18933
12	1	Nameplate	20729	20729	20729	20729	20729	20729	20729	20729	20729	20729	20729	20729	20729	20729
13	13	Lock Washer, M8	15222	15222	15222	15222	15222	15222	15222	15222	15222	15222	15222	15222	15222	15222
14	4	Screw, M8	15886	15886	15886	16021	16021	15886	15886	15886	15886	15886	15886	15886	15886	15886
15	1	Spark Plug	10014597	10014597	10014597	10019728	10019728	10019728	10019728	10019728	23045	23045	23045	23045	23045	23045
16	1	Peepsight	10509	10509	10509	10509	10509	10509	10509	10509	13225	13225	10509	10509	10509	10509
17	4	Pressure Tap	13445	13445	13445	13445	13445	13445	13445	13445	13445	13445	13445	13445	13445	13445
18	1	Flametrod	10002242-1	10002242-1	10002242-1	10002242-1	10002242-1	10002242-2	10002242-2	10002242-2	N/A	N/A	N/A	N/A	N/A	N/A
19	1	High Grade Flametrod	10019729-1	10019729-1	10019729-1	10019729-1	10019729-1	10019729-2	10019729-2	10019729-2	N/A	N/A	N/A	N/A	N/A	N/A
20	2	O-ring	14777	14777	14777	17037	17037	14778	14778	14778	14778	14778	14781	14781	14781	14781
21	1	Office Plate, NG	14191-13	14191-8	14191-6	14934-17	14934-10	14188-4	14188-4	14188-4	14188-3	14188-3	14802-14	14802-14	14802-4	14802-7
22	1	Office Plate, PR	14191-14	14191-13	14191-8	14934-13	14934-3	14188-4	14188-4	14188-4	14188-19	14188-3	14802-17	14802-17	14802-20	14802-13
23	1	Office Plate, BU	14191-14	14191-13	14191-8	14934-12	14934-2	14188-4	14188-4	14188-4	14188-3	14188-3	14802-16	14802-16	14802-19	14802-20
24	1	Inlet Block, Gas, NPT	3974-4	3974-4	3974-2	7001-1	7001-1	3973-3	3973-3	3973-3	3973-2	3973-2	3996-3	3996-3	3996-3	3996-3
25	1	Inlet Block, Gas, Rc	3974-3	3974-3	3974-1	7001-3	7001-3	3973-1	3973-1	3973-1	9373-10	3973-10	3996-4	3996-4	3996-4	3996-4
26	4	Screw, M8	15887	15887	15887	15893	15893	15893	15893	15893	15893	15893	15888	15888	15888	15888
27	4	Screw, M8	15893	15893	15893	20890	20890	15888	15888	15888	15892	15892	15892	15892	15892	15892
28	8	Thread Insert	N/A	N/A	N/A	N/A	N/A	N/A	N/A	N/A	N/A	20304	20304	20304	N/A	N/A
29	1	Inlet Block, Air, NPT	7001-2	7001-2	3973-2	7108-2	7108-2	3996-1	3996-1	3996-1	100041	N/A	N/A	N/A	N/A	N/A
30	1	Inlet Block, Air, Rc	7001-4	7001-4	3973-10	7108-3	7108-3	3996-2	3996-2	3996-2	100041-1	N/A	N/A	N/A	N/A	N/A
31	1	Inlet, Welded, Air	N/A	N/A	N/A	N/A	N/A	N/A	N/A	N/A	100040	100044	101111	101111	N/A	N/A
32	1	Inlet, Flanged, Air	N/A	N/A	N/A	N/A	N/A	N/A	N/A	N/A	N/A	N/A	N/A	N/A	N/A	N/A
33	1	Office Plate, Air	14934-6	14934-7	14188-5	20362-5	20362-6	14802-1	14802-3	14802-8	10039-1	20152-1	10002627-3	10002627-2	10005107-1	10005107-4
34	1	Block & Holder Assy, HV	187265-1	187265-2	100234-1	187329-68	187328-68	187302-68	187299-68	187317-68	187315-68	100015-68	10004665-68	10004665-68	10007035-68	10007036-68
35	1	Block & Holder Assy, MV	187265-2	187265-3	100234-2	187329-68	187328-68	187330-68	187298-68	187316-68	187314-68	100016-68	10004666-68	10004666-68	10007632-68	10007632-68
36	1	Down Fired Block & Holder, HV	N/A	N/A	N/A	10025728	10025726	10025724	10025722	10025720	10025718	10025716	10025715	10025712	10025711	10025710
37	1	Down Fired Block & Holder, MV	N/A	N/A	N/A	10025728	10025727	10025725	10025723	10025721	10025719	10025717	10025712	10025712	10025711	10025710
38	1	Combustor, Alloy, HV	108715-1	108715-2	108715-3	21747-2	21747-1	17182	15214	15260	108721	100042	10003218-1	10003218-2	10005394-1	10005394-2
39	1	Combustor, Alloy, MV	108715-2	108715-3	108715-4	21747-1	21747-3	17183	15213	15259	108721-1	100043	10003218-2	10003218-3	10007168	10007168
40	1	Gasket, Silicon Carbide	19971	19971	19971	10005080	10005080	10005	10005	10005	N/A	N/A	N/A	N/A	N/A	N/A
41	1	Retaining Ring, Silicon Carbide	19970	19970	19970	20464	20464	10003	10003	10003	N/A	N/A	N/A	N/A	N/A	N/A
42	1	Combustor, SiC, HV	17046-1	17046-2	17046-3	21793-1	21793-2	17180	15262	15262	N/A	N/A	N/A	N/A	N/A	N/A
43	1	Combustor, SiC, MV	17046-2	17046-3	17046-4	21793-1	21793-3	17181	15216	15261	N/A	N/A	N/A	N/A	N/A	N/A
44	4	UV Scanner Adapter	18720	18720	18720	18720	18720	18720	18720	18720	18720	18720	18720	18720	18720	18720
45	4	Screw, FH	10001	10001	10001	10001	10001	10001	10001	10001	10001	10001	10001	10001	10001	10001
46	2	Gasket, Air Inlet	N/A	N/A	N/A	N/A	N/A	N/A	N/A	N/A	N/A	N/A	N/A	N/A	N/A	N/A
47	1	Gasket, Alloy Tube, Body	N/A	N/A	N/A	N/A	N/A	N/A	N/A	N/A	N/A	N/A	N/A	N/A	N/A	N/A
48	1	Gasket, Body, Adapter Plate	N/A	N/A	N/A	N/A	N/A	N/A	N/A	N/A	N/A	N/A	N/A	N/A	N/A	N/A
49	31	Gasket, Rear Cover	N/A	N/A	N/A	N/A	N/A	N/A	N/A	N/A	N/A	N/A	N/A	N/A	N/A	N/A
50	1	Plug, 1/8"	N/A	N/A	N/A	15398	15398	15398	15398	15398	15398	15398	15398	15398	15398	15398
51	12	Washer, Flat	N/A	N/A	N/A	N/A	N/A	N/A	N/A	N/A	N/A	N/A	N/A	N/A	N/A	N/A
52	12	Nut, M8	N/A	N/A	N/A	N/A	N/A	N/A	N/A	N/A	N/A	N/A	N/A	N/A	N/A	N/A
53	1	Adapter, Plate, Rear Cover	N/A	N/A	N/A	N/A	N/A	N/A	N/A	N/A	N/A	20150	N/A	N/A	10004488	10004488

THERMJET ILLUSTRATED PARTS DRAWING MODELS TJ0015 THROUGH TJ1000

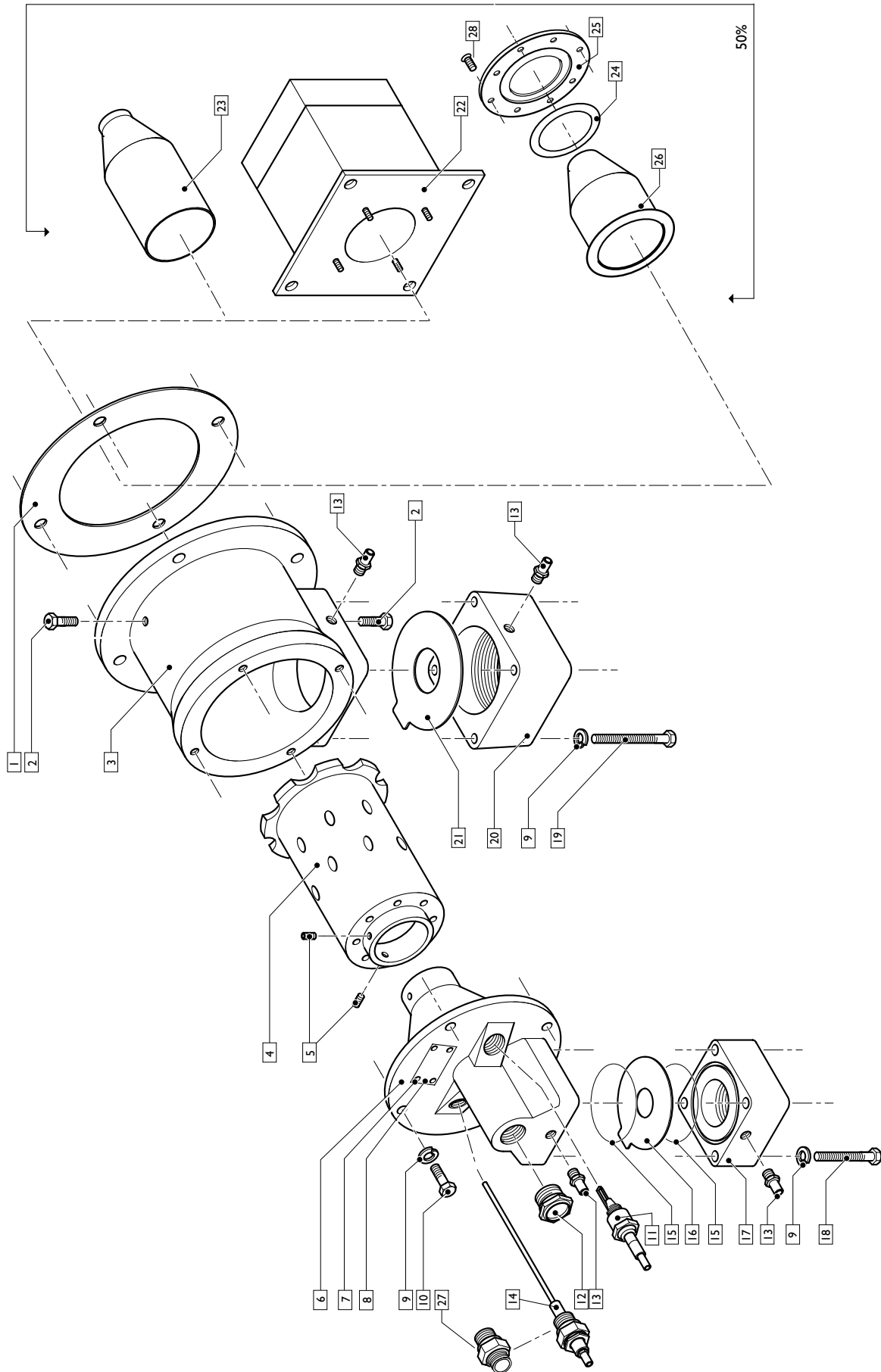

THERMJET ILLUSTRATED PARTS DRAWING MODELS TJI500 AND TJ2000

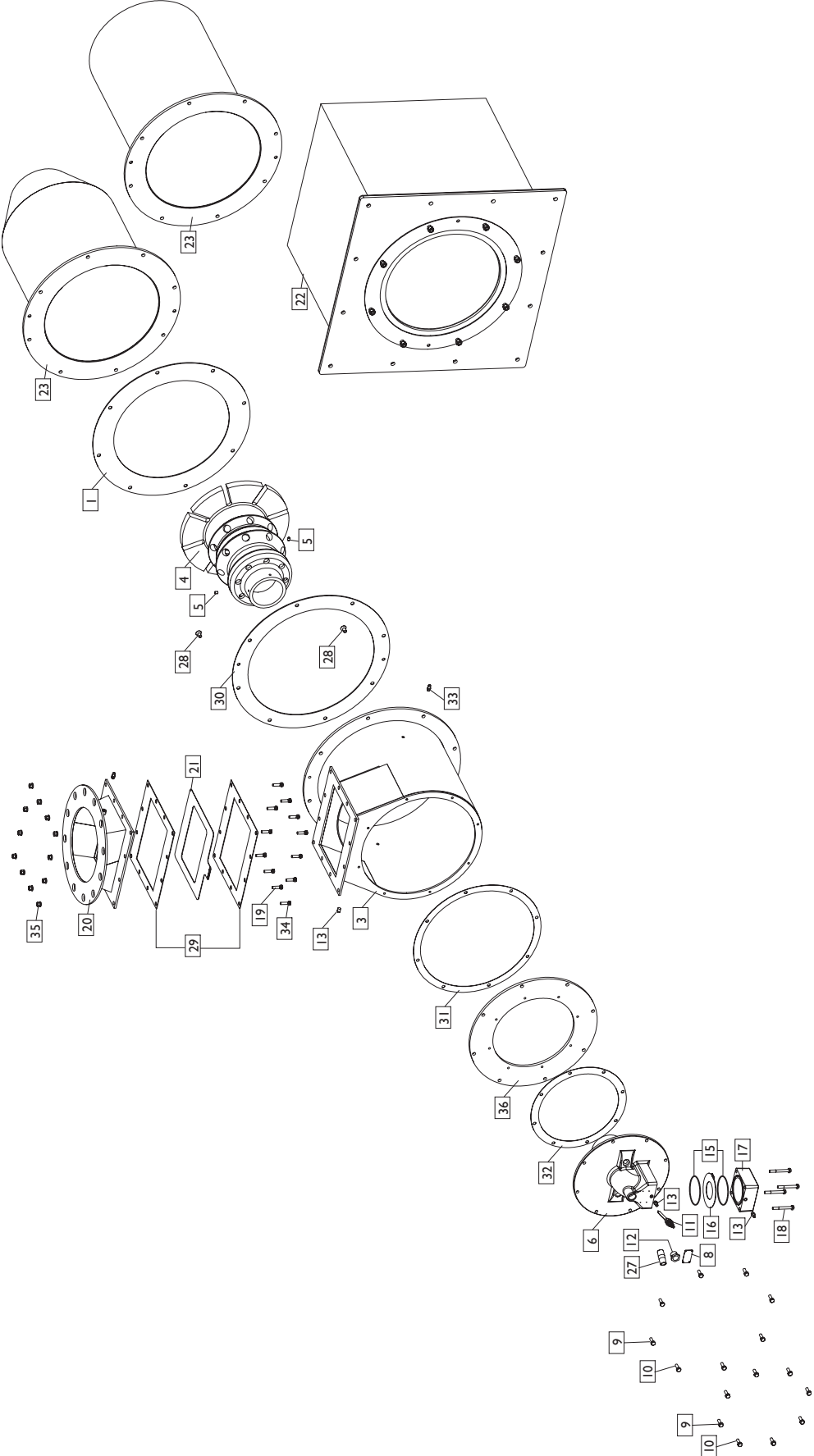

ThermJet Illustrated Parts List (Repeated)

Pos. No.	Qty.	Description	TJ0015	TJ0025	TJ0040	TJ0050	TJ0075	TJ0100	TJ0150	TJ0200	TJ0300	TJ0500	TJ0750	TJ1000	TJ1500	TJ2000
1	1	Gasket, Mounting	17054	17054	17054	20422	20422	14932	14932	14932	10027	20151	10002831	10002831	10007206	10007206
2	1	Screw	16022	16022	16022	16022	16022	16022	16022	16022	N/A	N/A	N/A	N/A	N/A	N/A
3	1	Body	7031-1	7031-1	7118-1	7046-1	7046-1	3994	3994	3994	7036-1	7111-1	7124-3	7124-3	10006927	10006927
4	1	Nozzle, Cast Iron	7033-1	7033-2	7033-3	7133-1	7133-2	3997-1	3997-1	3997-1	7038-1	7116-1	10002813-1	10002813-1	10006112	10006112
		Nozzle, Stainless Steel	7125-1	7125-1	7125-1	7137-1	7137-1	7127-1	7127-1	7127-1	7128-1	7129-1	10007413-1	10007413-1	10007512	10007512
		Nozzle, Cast Iron, For Block	10026920	10026920	10026921	10026923	10026924	10026925	10026925	10026925	N/A	N/A	N/A	N/A	N/A	N/A
		Nozzle, Stainless Steel, For Block	10026927	10026927	10026928	10026929	10026930	10026931	10026931	10026931	N/A	N/A	N/A	N/A	N/A	N/A
5	2	Set Screw	19969	19969	19969	15885	15885	15885	15885	15885	15885	15885	21598	21598	21598	21598
6	1	Stainless Set Screw	10024662	10024662	10024662	10024662	10024662	10024662	10024662	10024662	10024662	10024662	10024662	10024662	10024662	10024662
7	4	Screw, #2 Drive	7032-1	7032-1	7032-1	3998-1	3998-1	3995	3995	3995-1	7037-1	7037-1	10002812	10002812	10002812	10002812
8	1	Nameplate	18933	18933	18933	18933	18933	18933	18933	18933	18933	18933	18933	18933	18933	18933
9	13	Lock Washer, M8	15222	15222	15222	15222	15222	15222	15222	15222	15222	15222	15222	15222	15222	15222
10	4	Screw, M8	15886	15886	15886	16021	16021	15886	15886	15886	15886	15886	15886	15886	15886	15886
11	1	Spark Plug	10014597	10014597	10014597	10014597	10014597	10019728	10019728	10019728	10019728	10019728	10019728	10019728	10019728	10019728
12	1	Peepsight	10509	10509	10509	10509	10509	10509	10509	10509	10509	10509	10509	10509	10509	10509
13	4	Pressure Tap	13445	13445	13445	13445	13445	13445	13445	13445	13445	13445	13445	13445	13445	13445
14	1	Flamerod	10002242-1	10002242-1	10002242-1	10002242-1	10002242-1	10002242-2	10002242-2	10002242-2	N/A	N/A	N/A	N/A	N/A	N/A
		High Grade Flamerod	10019729-1	10019729-1	10019729-1	10019729-1	10019729-1	10019729-2	10019729-2	10019729-2	N/A	N/A	N/A	N/A	N/A	N/A
15	2	O-ring	14777	14777	14777	17037	17037	14778	14778	14778	14778	14778	14781	14781	14781	14781
16	1	Office Plate, NG	14191-13	14191-8	14191-6	14934-17	14188-4	14188-4	14188-4	14188-4	14188-4	14188-5	14802-14	14802-15	14802-4	14802-7
		Office Plate, PR	14191-14	14191-13	14191-8	14934-13	14934-3	14188-7	14188-4	14188-4	14188-19	14188-3	14802-17	14802-19	14802-20	14802-13
		Office Plate, BU	14191-14	14191-13	14191-8	14934-12	14934-2	14188-7	14188-4	14188-4	14188-3	14802-16	14802-18	14802-18	14802-19	14802-20
17	1	Inlet Block, Gas, NPT	3974-4	3974-4	3974-4	7001-1	7001-1	3973-3	3973-3	3973-3	3973-2	3973-2	3996-3	3996-3	3996-3	3996-3
		Inlet Block, Gas, Rc	3974-3	3974-3	3974-3	7001-3	7001-3	3973-1	3973-1	3973-1	9373-10	3973-10	3996-4	3996-4	3996-4	3996-4
18	4	Screw, M8	15887	15887	15887	15893	15893	15893	15893	15893	15893	15893	15888	15888	15888	15888
19	4	Screw, M8	15893	15893	15893	20890	20890	15888	15888	15888	15892	15892	15892	15892	20579	20579
		Thread Insert	N/A	N/A	N/A	N/A	N/A	N/A	N/A	N/A	N/A	20304	20304	20304	N/A	N/A
20	1	Inlet Block, Air, NPT	7001-2	7001-2	3973-2	7108-2	7108-2	3996-1	3996-1	3996-1	100041	N/A	N/A	N/A	N/A	N/A
		Inlet Block, Air, Rc	7001-4	7001-4	3973-10	7108-3	7108-3	3996-2	3996-2	3996-2	100041-1	N/A	N/A	N/A	N/A	N/A
		Inlet, Welded, Air	N/A	N/A	N/A	N/A	N/A	N/A	N/A	N/A	100040	100044	101111	101111	N/A	N/A
		Inlet, Flanged, Air	N/A	N/A	N/A	N/A	N/A	N/A	N/A	N/A	N/A	N/A	N/A	N/A	N/A	N/A
21	1	Office Plate, Air	14934-6	14934-7	14188-5	20362-5	20362-6	14802-1	14802-3	14802-8	10039-1	20152-1	10002627-3	10002627-2	10005107-1	10005107-4
22	1	Block & Holder Assy, HV	187265-1	187265-2	100234-1	187329-68	187329-68	187302-68	187299-68	187317-68	187315-68	100015-68	10004465-68	10004466-68	10007035-68	10007036-68
		Block & Holder Assy, MV	187265-2	187265-3	100234-2	187329-68	187329-68	187300-68	187298-68	187316-68	187314-68	100016-68	10004466-68	10004467-68	10007632-68	10007633-68
		Down Fired Block & Holder, HV	N/A	N/A	N/A	10025728	10025726	10025724	10025722	10025720	10025718	10025716	10025715	10025712	10025711	10025708
		Down Fired Block & Holder, MV	N/A	N/A	N/A	10025728	10025726	10025725	10025723	10025721	10025719	10025717	10025716	10025713	10025710	10025707
23	1	Combustor, Alloy, HV	108715-2	108715-2	108715-3	21747-2	21747-2	17182	15214	15260	108721	100042	10003218-1	10003218-2	10005394-1	10005394-2
		Combustor, Alloy, MV	108715-2	108715-3	108715-4	21747-1	21747-3	17183	15213	15259	108721-1	100043	10003218-2	10003218-3	10007168	N/A
24	1	Gasket, Silicon Carbide	19971	19971	19971	10005080	10005080	10005	10005	10005	N/A	N/A	N/A	N/A	N/A	N/A
25	1	Retaining Ring, Silicon Carbide	19970	19970	19970	20464	20464	10003	10003	10003	N/A	N/A	N/A	N/A	N/A	N/A
26	1	Combustor, SiC, HV	17046-1	17046-2	17046-3	21793-2	21793-1	17180	15262	N/A	N/A	N/A	N/A	N/A	N/A	N/A
		Combustor, SiC, MV	17046-2	17046-3	17046-4	21793-3	21793-3	17181	15216	15261	N/A	N/A	N/A	N/A	N/A	N/A
27	4	Screw, FH	18720	18720	18720	18720	18720	18720	18720	18720	18720	18720	18720	18720	18720	18720
28	4	Screw, FH	10001	10001	10001	10001	10001	10001	10001	10001	10001	10001	10001	10001	10001	10001
29	2	Gasket, Air Inlet	N/A	N/A	N/A	N/A	N/A	N/A	N/A	N/A	N/A	N/A	N/A	N/A	21587	21587
30	1	Gasket, Alloy Tube, Body	N/A	N/A	N/A	N/A	N/A	N/A	N/A	N/A	N/A	N/A	N/A	N/A	10006989	10006989
31	1	Gasket, Body, Adapter Plate	N/A	N/A	N/A	N/A	N/A	N/A	N/A	N/A	N/A	N/A	N/A	N/A	10006940	10006940
32	1	Gasket, Rear Cover	N/A	N/A	N/A	N/A	N/A	N/A	N/A	N/A	N/A	N/A	N/A	N/A	10007000	10007000
33	1	Plug, 1/8"	N/A	N/A	15398	15398	15398	15398	15398	15398	15398	15398	15398	15398	15398	15398
34	12	Washer, Flat	N/A	N/A	N/A	N/A	N/A	N/A	N/A	N/A	N/A	N/A	N/A	N/A	15643	15643
35	12	Nut, M8	N/A	N/A	N/A	N/A	N/A	N/A	N/A	N/A	N/A	N/A	N/A	N/A	90804	90804
36	1	Adapter, Plate, Rear Cover	N/A	N/A	N/A	N/A	N/A	N/A	N/A	N/A	N/A	20150	N/A	N/A	10004488	10004488



Offered By:

Power Equipment Company
2011 Williamsburg Road
Richmond, Virginia 23231
Phone (804) 236-3800
Fax (804) 236-3882

www.peconet.com